

PARTS LIST - 2 PERSON ASSEMBLY:-		
A	PRE-ASSEMBLED TABLE TOP	1 no.
B	END A-FRAME	2 no.
C	PRE-ASSEMBLED BENCH	2 no.
D	70mm S/STEEL SCREWS	40 no.
E	90mm S/STEEL SCREWS	16 no.

TOOLS:-
POWER DRILL WITH P22 BIT
G CLAMPS

IMPORTANT:-

Ensure that you are familiar with these assembly instructions prior to commencing assembly.

We will not accept any claims resulting from products that have been wrongly assembled.

Employ safe lifting procedures when handling components.

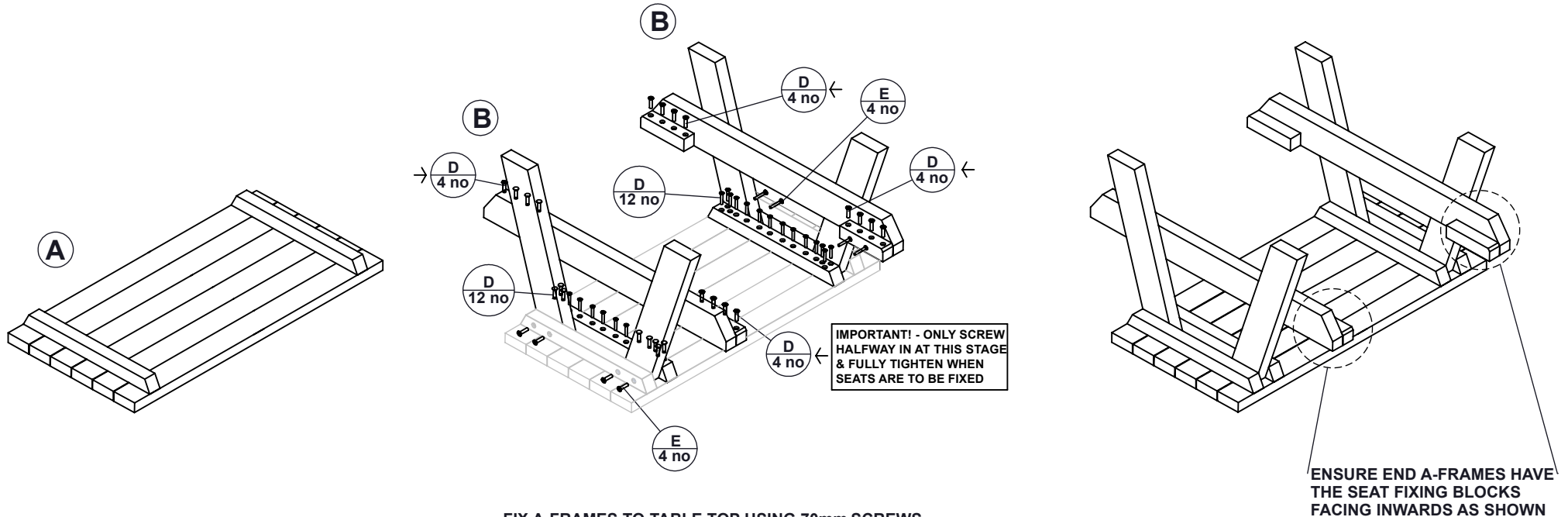

BEGIN ASSEMBLY WITH TABLE TOP TURNED UPSIDE DOWN

FIX A-FRAMES TO TABLE TOP USING 70mm SCREWS THROUGH PRE-DRILLED HOLES IN FIXING BARS

BEFORE TIGHTENING SCREWS CHECK THAT THE PICNIC TABLE LEG IS CENTRAL TO THE TABLE TOP. CLAMPING THE LEGS TO THE TABLE BLOCKS CAN ASSIST ASSEMBLY

ENSURE END A-FRAMES HAVE THE SEAT FIXING BLOCKS FACING INWARDS AS SHOWN

Help and support:-

Please contact us using the telephone number or email address as stated on your shipping documents.

1 MTR. A-FRAME PICNIC TABLE:
Assembly Guide - 1 of 2.



Earth - Anchors

0208 684 9601

TOOLS:-

POWER DRILL WITH PZ2 BIT

MEASURING TAPE & STRAIGHT EDGE

IMPORTANT:-

Ensure that you are familiar with these assembly instructions prior to commencing assembly.

We will not accept any claims resulting from products that have been wrongly assembled.

Employ safe lifting procedures when handling components.

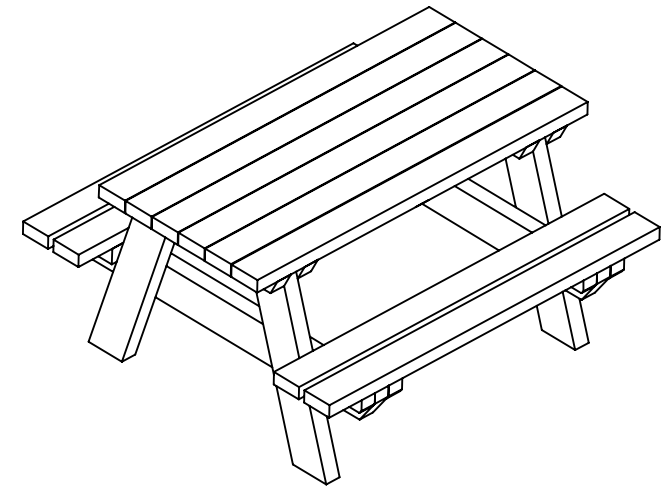
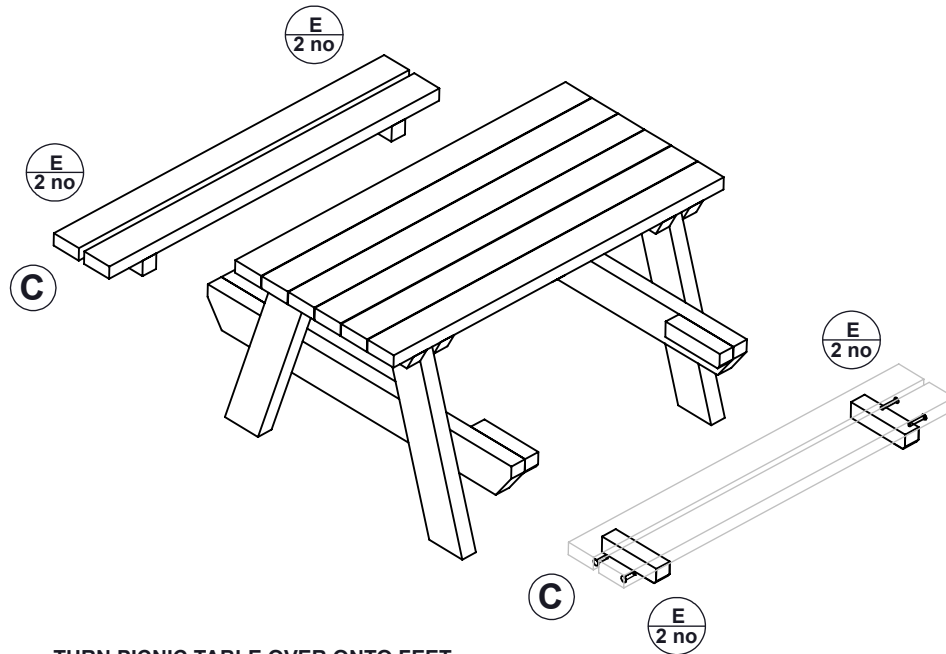

TURN PICNIC TABLE OVER ONTO FEET
& FIX PRE-ASSEMBLED SEATS USING 90mm
SCREWS THROUGH PRE-DRILLED HOLES HORIZONTAL
IN SEAT FIXING BLOCKS

**BEFORE FULLY TIGHTENING ALL SCREWS
CHECK THAT THE SEATS ARE SQUARE**

Help and support:-

Please contact us using the telephone number
or email address as stated on your shipping documents.

**1 MTR. A-FRAME PICNIC TABLE:
Assembly Guide - 2 of 2.**



Earth - Anchors

0208 684 9601