

COMPONENT LIST		
ITEM	DESCRIPTION	QTY
A	Table top	1
B	90mm screws	28
C	Standard A-frame leg	1
D	Standard A-frame leg with cross brace holes	1
E	Double mobility leg	1
F	70mm screws	52
G	Mobility seat pan	2

IMPORTANT:-
 Ensure that you are familiar with these assembly instructions prior to commencing assembly. We will not accept any claims resulting from products that have been wrongly assembled. Employ safe lifting procedures when handling components.

ONLY FIT SCREWS THROUGH THE COUNTERSUNK SIDE OF A HOLE.

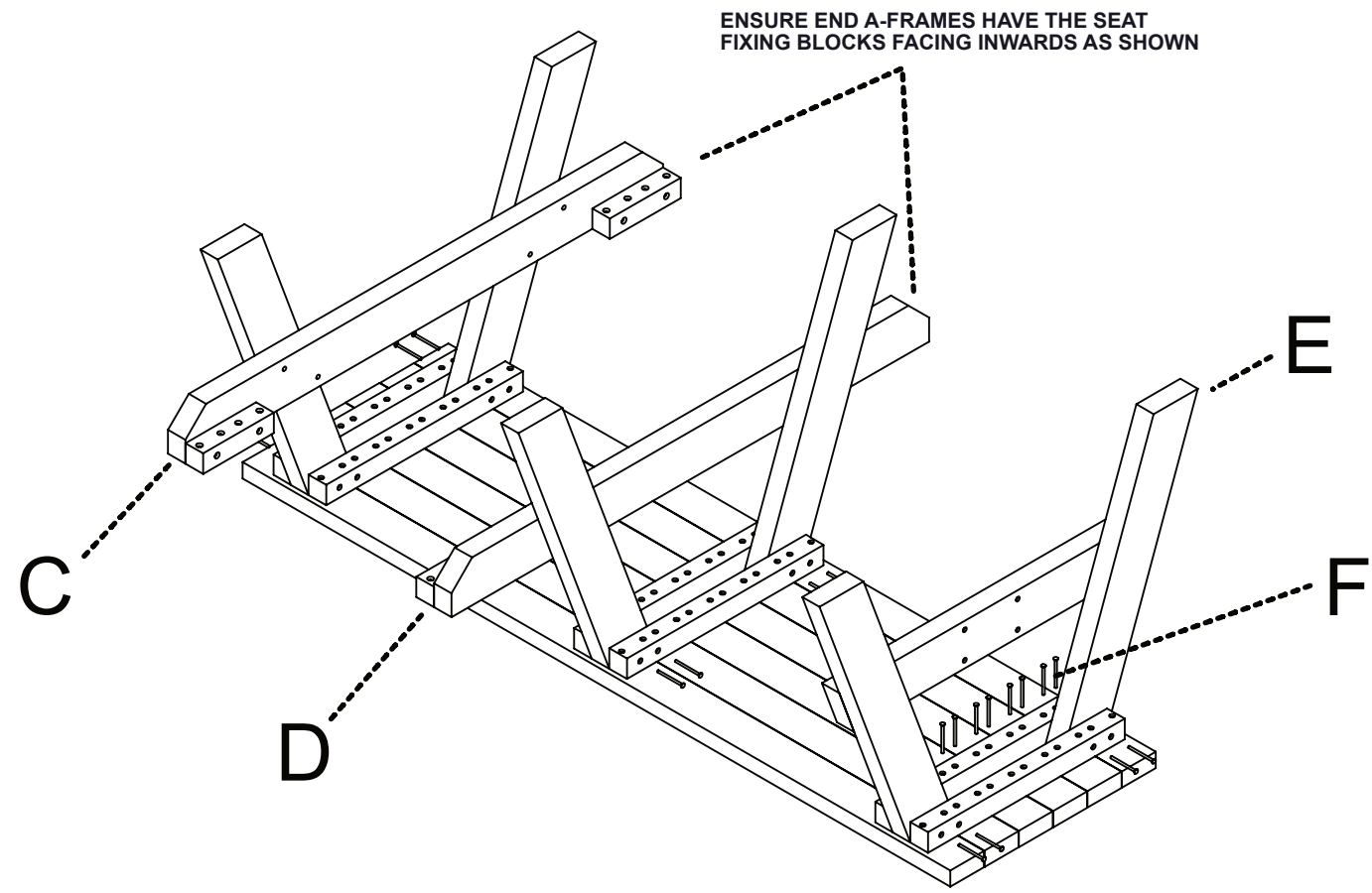
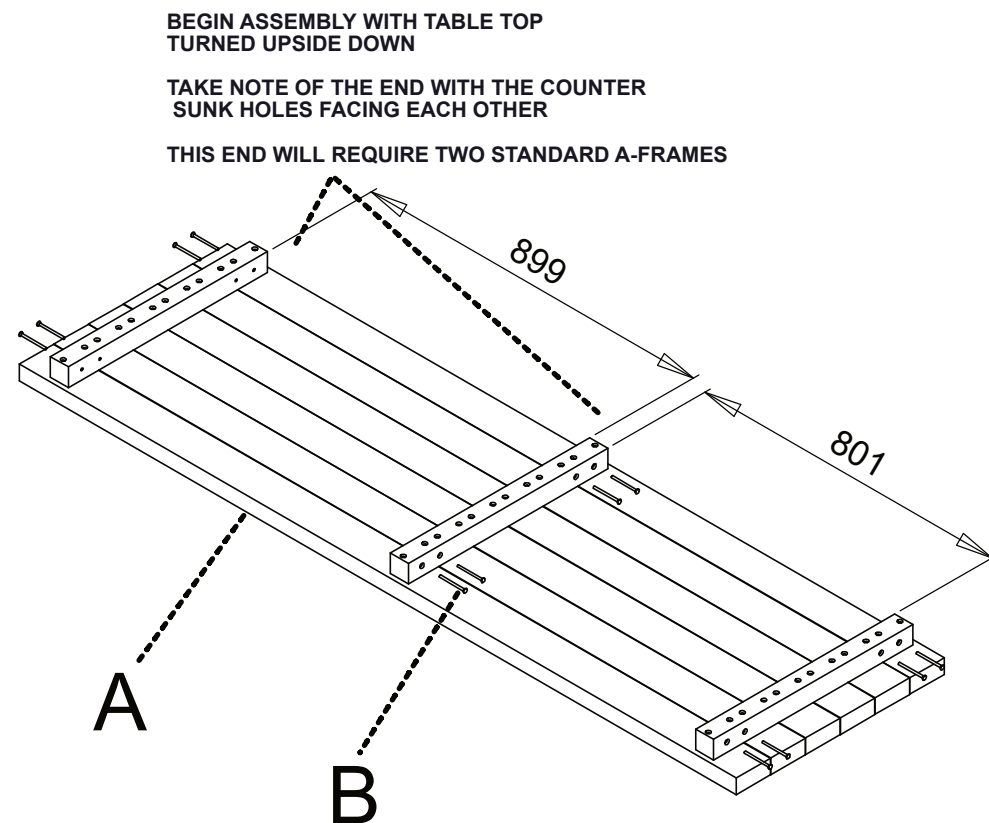

FIX A-FRAMES TO TABLE TOP USING 70mm SCREWS THROUGH PRE-DRILLED HOLES IN VERTICAL FIXING BARS ENSURE THAT SCREWS ENTER FROM COUNTER SUNK SIDE OF FIXING BAR.

THE MIDDLE LEG MUST HAVE THE ADDITIONAL FIXING HOLES IN THE MIDDLE OF THE CROSS BRACE

IMPORTANT
 USE CLAMPS WHEN FIXING THE LEGS IN TO PLACE AND SCREW THROUGH THE VERTICAL HOLES FIRST

2 MTR. DOUBLE A-FRAME PICNIC TABLE:
 Assembly Guide - 1 of 2.



Earth - Anchors

0208 684 9601

TOOLS:-
POWER DRILL WITH PZ2 BIT
G-Clamps

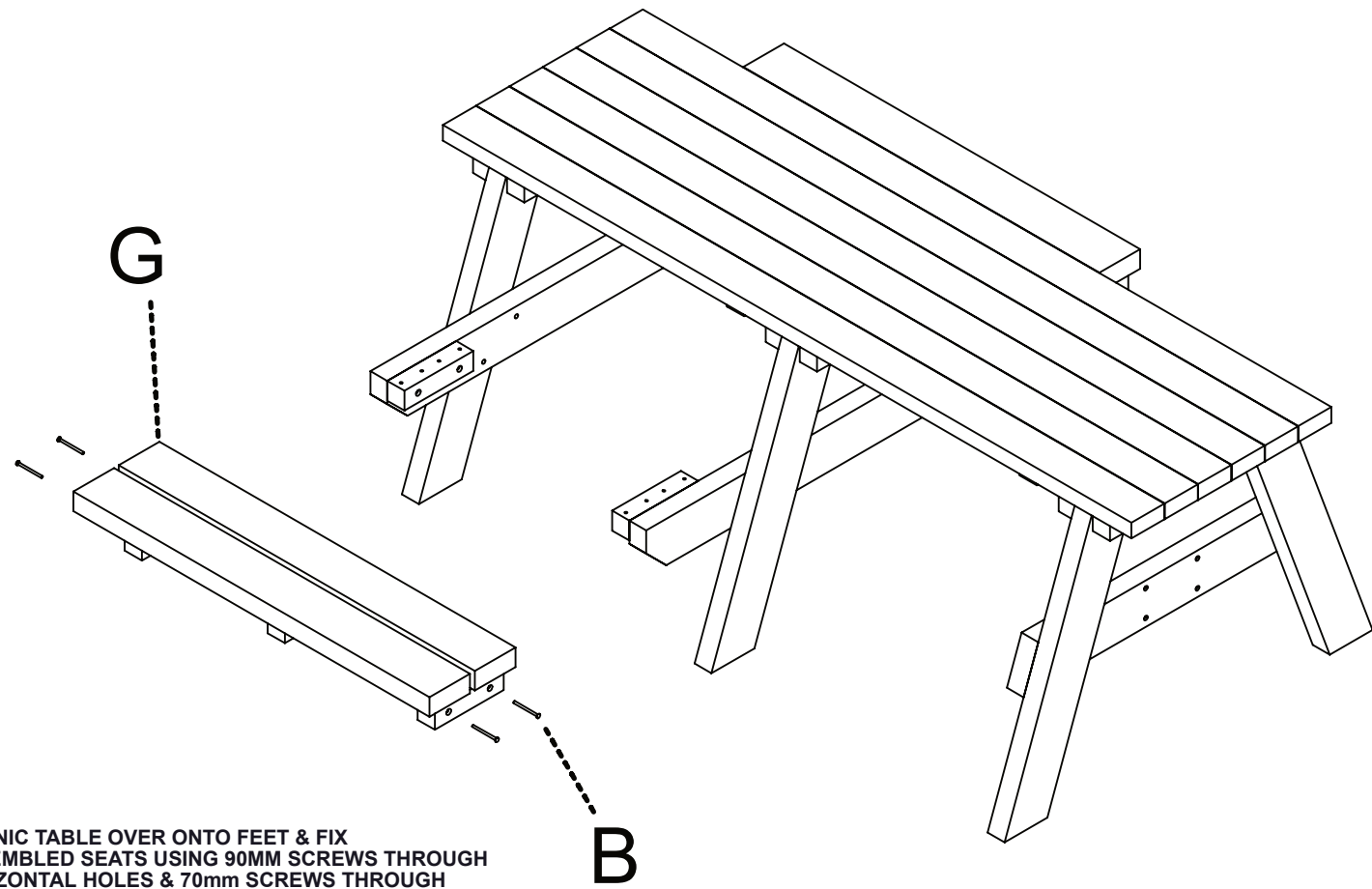

TURN PICNIC TABLE OVER ONTO FEET & FIX PRE-ASSEMBLED SEATS USING 90MM SCREWS THROUGH THE HORIZONTAL HOLES & 70mm SCREWS THROUGH PRE-DRILLED VERTICAL HOLES IN SEAT FIXING BLOCKS

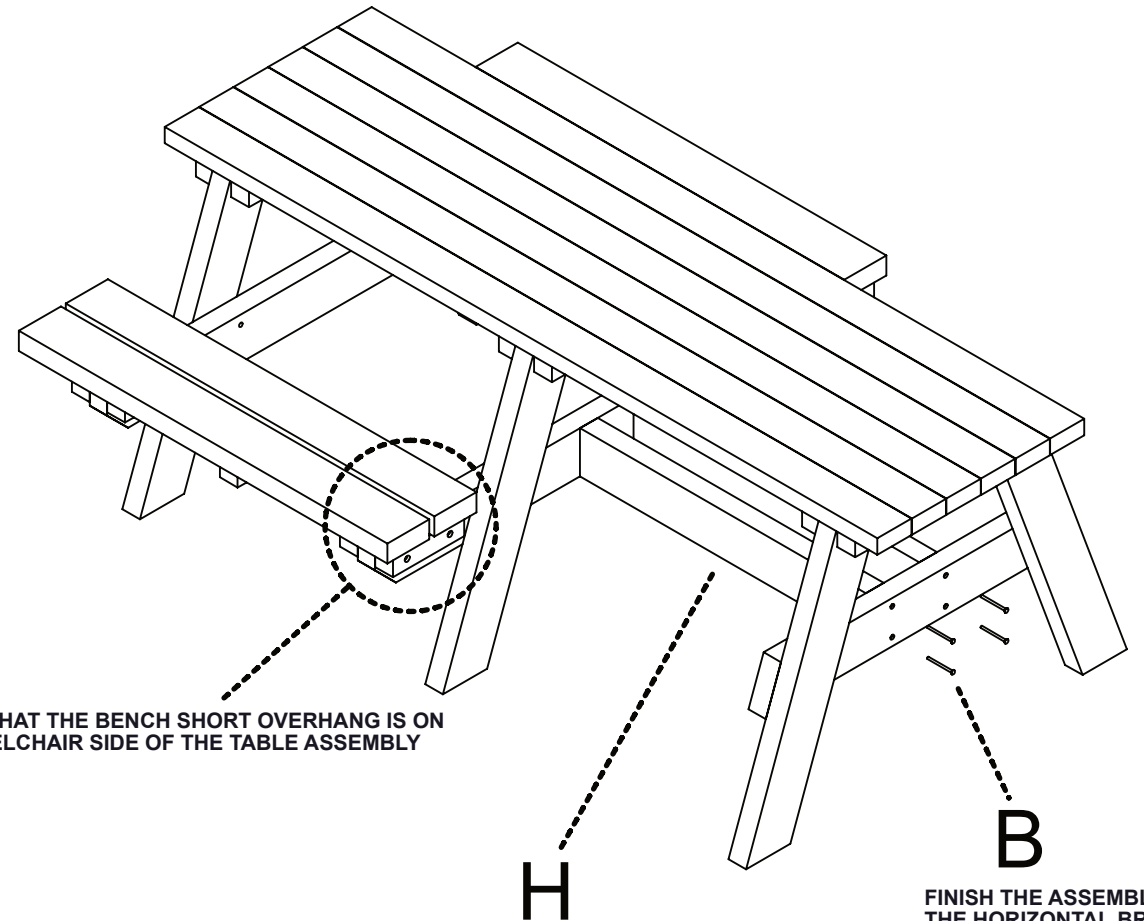

ENSURE THAT THE BENCH SHORT OVERHANG IS ON THE WHEELCHAIR SIDE OF THE TABLE ASSEMBLY

FINISH THE ASSEMBLY BY FITTING THE HORIZONTAL BRACES IN PLACE WITH 90MM SCREWS.

**2 MTR. DOUBLE A-FRAME
PICNIC TABLE:**
Assembly Guide - 2 of 2.



Earth - Anchors

0208 684 9601