

PARTS LIST - 2 PERSON ASSEMBLY:-		
A	PRE-ASSEMBLED TABLE TOP	1 no.
B	END A-FRAME	4 no.
D	PRE-ASSEMBLED SEAT (Long)	1 no.
D1	PRE-ASSEMBLED SEAT (Short)	2 no.
E	70mm S/STEEL SCREWS	64 no.
F	90mm S/STEEL SCREWS	32 no.

TOOLS:-	
POWER DRILL WITH PZ2 - HEAD BIT	
G CLAMPS / QUICK CLAMPS	

IMPORTANT:-

Ensure that you are familiar with these assembly instructions prior to commencing assembly.

We will not accept any claims resulting from products that have been wrongly assembled.

Employ safe lifting procedures when handling components.

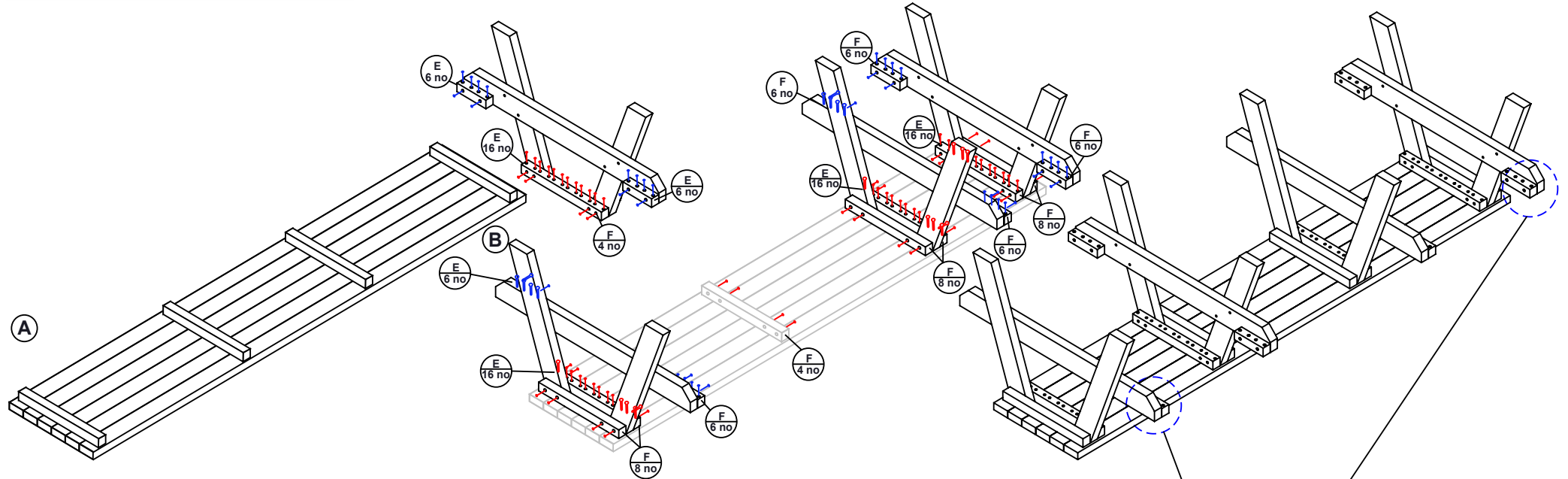

BEGIN ASSEMBLY WITH TABLE TOP TURNED UPSIDE DOWN

THE SIDE WITH THE SMALLER GAP BETWEEN THE FIXING BARS IS THE MOBILITY END AND SUCH REQUIRES THE CUT END FRAME

FIX A-FRAMES TO TABLE TOP USING 70mm SCREWS THROUGH PRE-DRILLED HOLES IN FIXING BARS

ENSURE THAT SCREWS ENTER FROM COUNTER SUNK SIDE OF FIXING BAR.

ENSURE END A-FRAMES HAVE THE SEAT FIXING BLOCKS FACING INWARDS AS SHOWN

IMPORTANT:-

USE CLAMPS WHEN FIXING THE LEGS IN TO PLACE AND SCREW THROUGH THE VERTICAL HOLES FIRST

3 MTR.W/CHAIR PICNIC TABLE:
 Assembly Guide - 1 of 2.

Earth Anchors Ltd

TOOLS:-
POWER DRILL WITH PHILIPS-HEAD BIT
MEASURING TAPE & STRAIGHT EDGE

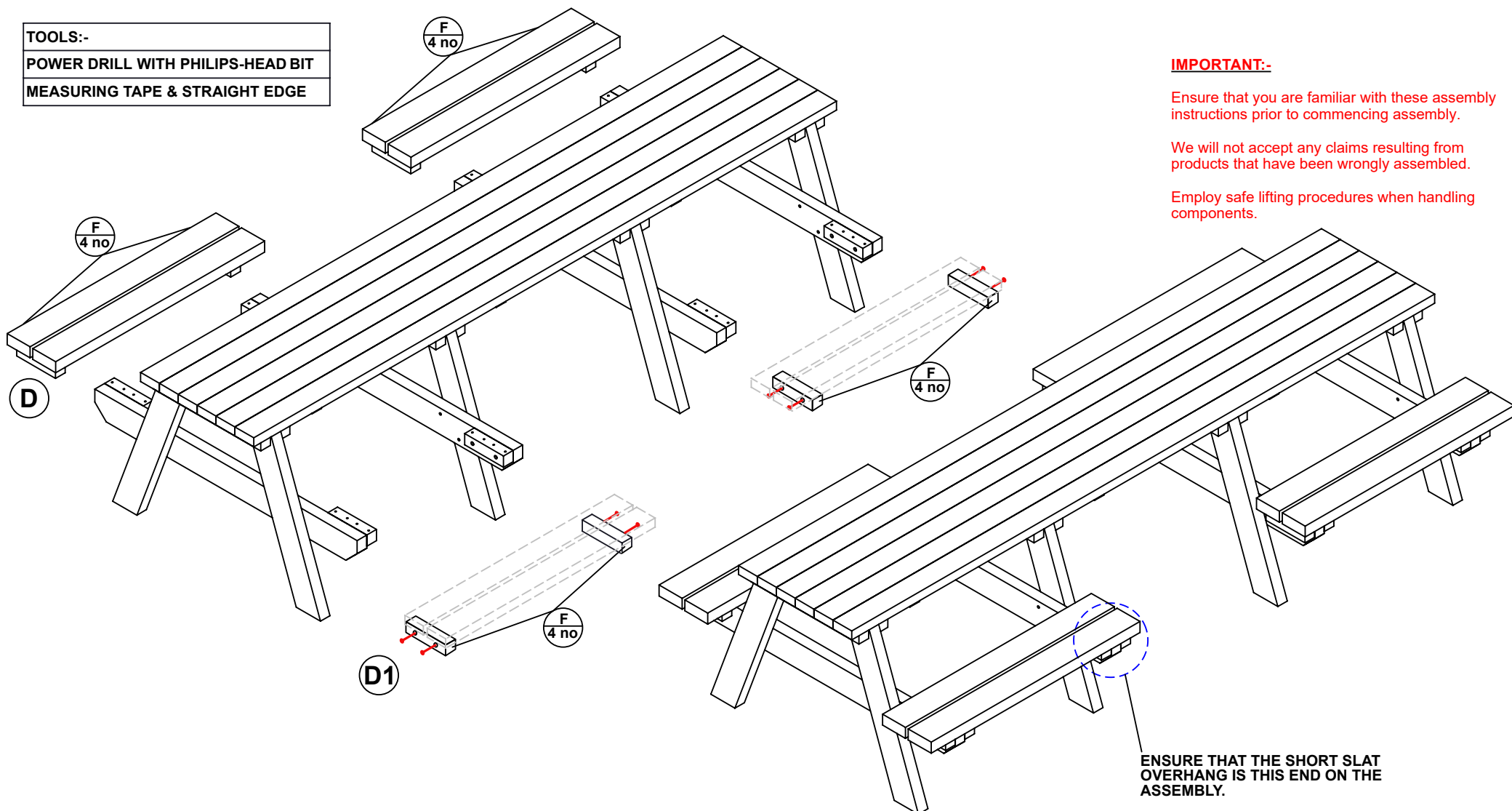

IMPORTANT:-

Ensure that you are familiar with these assembly instructions prior to commencing assembly.

We will not accept any claims resulting from products that have been wrongly assembled.

Employ safe lifting procedures when handling components.

TURN PICNIC TABLE OVER ONTO FEET
 & FIX PRE-ASSEMBLED SEATS USING 70mm
 SCREWS THROUGH PRE-DRILLED VERTICAL HOES
 IN SEAT FIXING BLOCKS & 90MM SCREWS THROUGH
 THE HORIZONTAL HOLES

Help and support:-

Please contact us using the telephone number
 or email address as stated on your shipping documents.

3 MTR.W/CHAIR PICNIC TABLE:
Assembly Guide - 2 of 2.

Earth Anchors Ltd