

Kit Components	
Item	Qty
Leg Assembly	3
Table Top Assembly	1
Bench Assembly	2
M10 Nut Protector	6
M10 x 100 Coach Bolt, Washer & Nut	6
Safety Cap Cover	6
5 x 70 Stainless Screws	12

Tools Required
 17mm Socket spanner
 Drill Driver with PZ2 bit
 Mallet

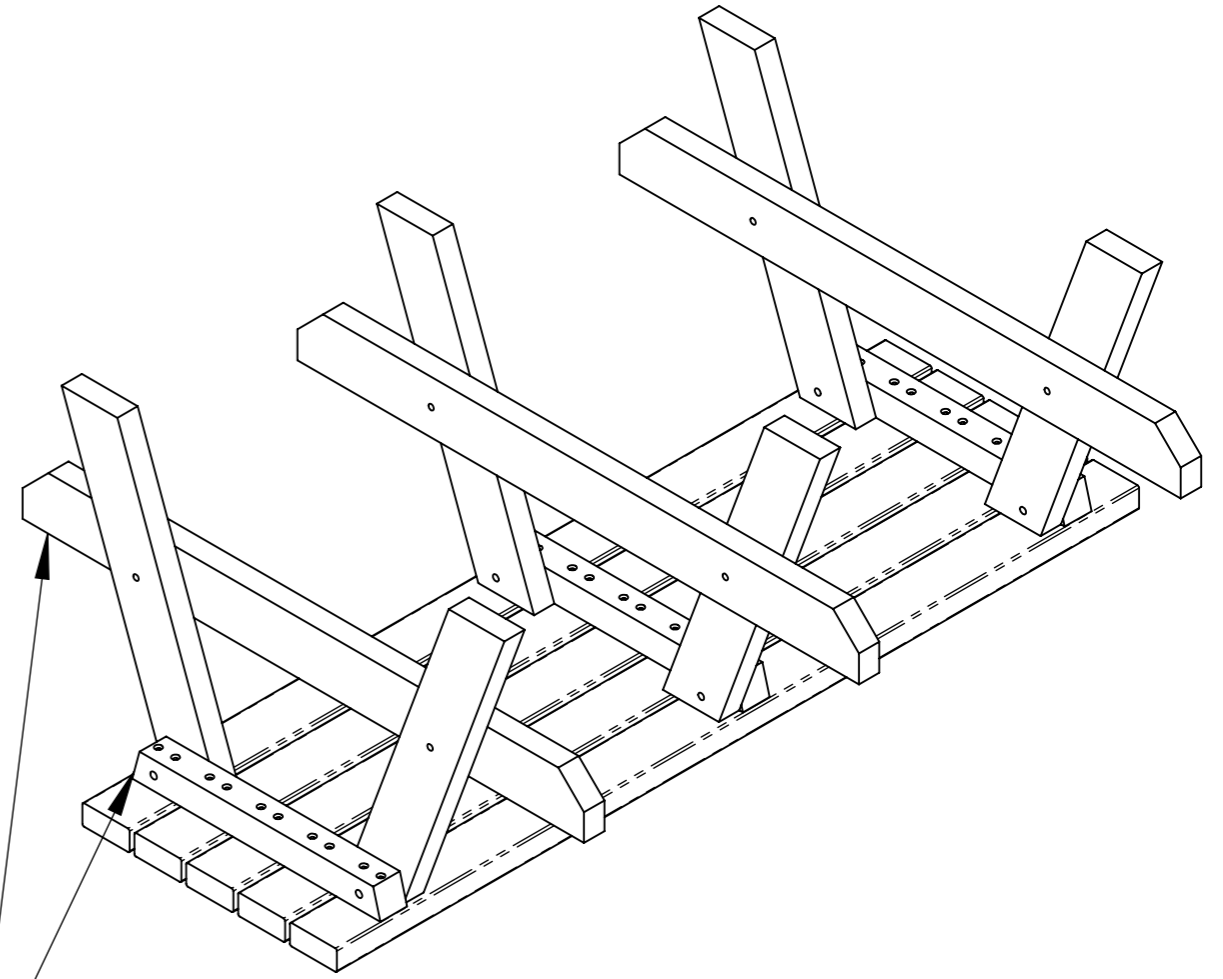

IMPORTANT
 Note how the horizontal cross bar on the leg is positioned to be on the opposite side to the block affixed to the table top.

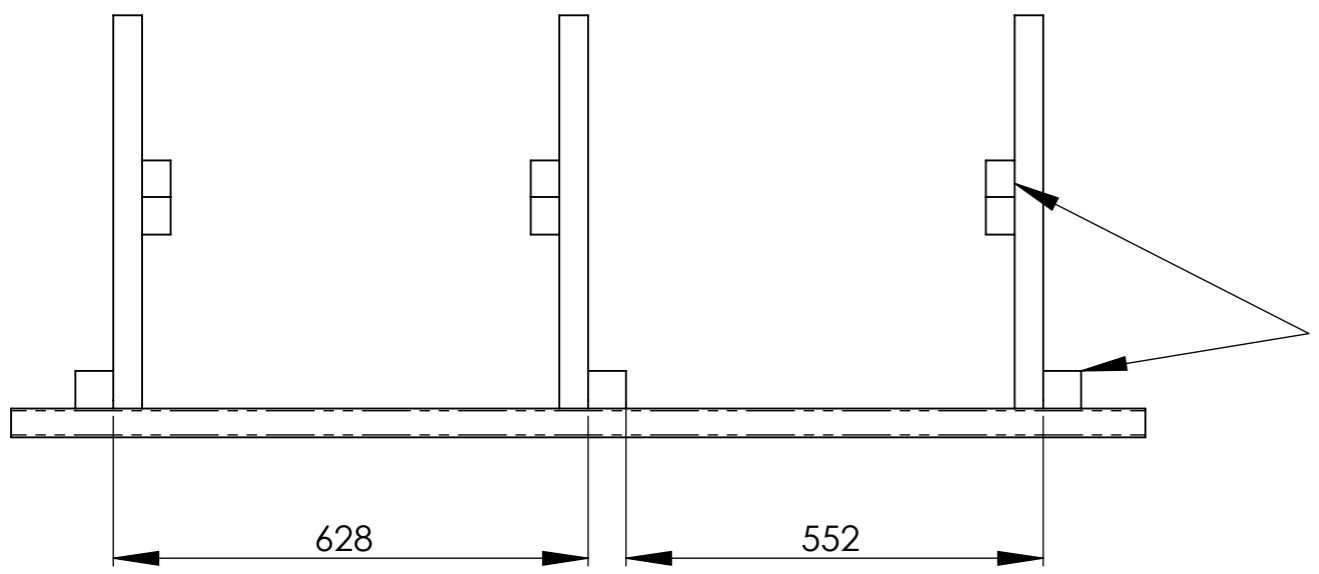

Note:
 A rubber mallet can be used to aid the assembly when fitting the coachbolts

1. Lay the table top face down on flat ground.
 Look for the "C" marking on the blocks fitted to the table top. The legs are to be bolted on the "C" side of the block.
 Loosely bolt together using the M10 x 100 Coachbolts, nut and washer.

Earth Anchors Ltd	
TITLE: Infant Picnic Table Assembly Instructions - Page 1	
DWG NO. EA2200500	REVISION 1
SHEET 1 OF 2	

	NAME	DATE
DRAWN	AC	09/09/22
SW-DWG NAME:		

2.
Flip the table on to its legs.

Position the benches so that the blocks are flush with the end of the leg support.
Applying downwards pressure to the bench assembly screw through the horizontal holes in the bench blocks and into the leg assembly.

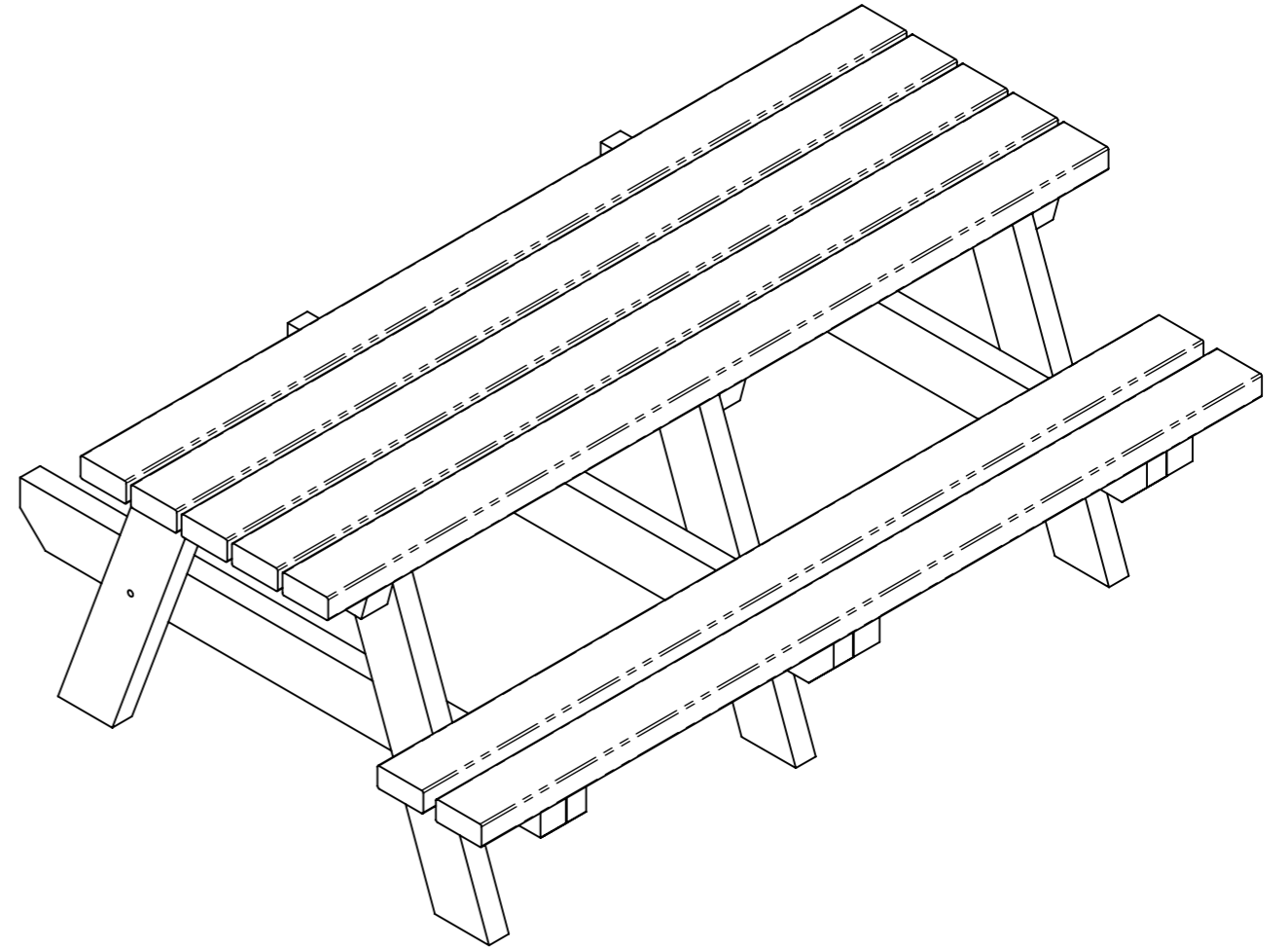
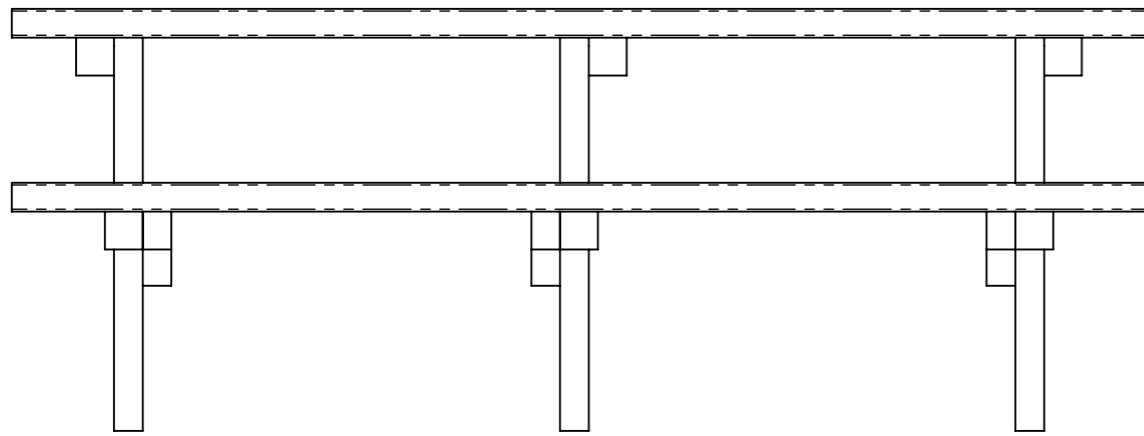

3.
To finish the assembly tighten all bolts. Fit nut covers on the table top mounting bolts.

The leg bolts have been left loose to aid assembly of the table. These can now be tightened up and have the safety cap cover pushed in to place. Do not over tighten as this can crack the bolt cup.

Note:
If assembling multi coloured tables ensure the benches are fitted so that the colour order is as follow:
Red, purple, blue, green, yellow, orange, red, blue, purple.

Earth Anchors Ltd

TITLE:

Infant Picnic Table

Assembly Instructions - Page 2

DWG NO.

EA2200501

REVISION

1

	NAME	DATE
DRAWN	AC	09/09/22
SW-DWG NAME:		