



Earth Anchors

furniture for parks and streets.

Table Data Sheet

Monolith Picnic Table



Colour Information:

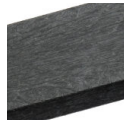

Black



Brown

Specification:

Table Length: 1500/1800/2000mm
Table height: 750mm
Table width: 640mm
Weight: 125/152/160kg

Product Information

Description

A simple and chunky picnic table suitable for use with the monolith benches for a space saving table setup. Made entirely from Forest-Saver recycled plastic.

Features

Supplied fully assembled.
Guaranteed for 25 years against material failure.

Materials

Forest-Saver recycled plastic.
Stainless steel fixings.

Optional Extras

Customise with engraving or plaques.
Ground fixing kits.



Earth Anchors Ltd

Unit 3 lo Centre, Salbrook Road Industrial Estate, Salfords, Surrey, RH1 5GJ

Tel: 020 8684 9601

www.earth-anchors.com



Earth Anchors

furniture for parks and streets.

Table Data Sheet

Monolith Picnic Table

Ground Fixings

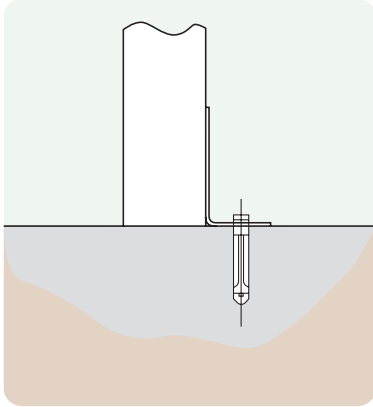

Bolt down
Available for a variety of hard surfaces.

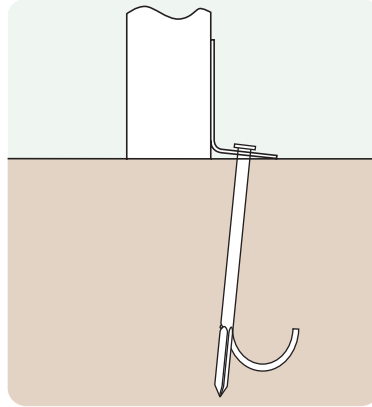

Anchored
Soft ground fixing kit for grass.

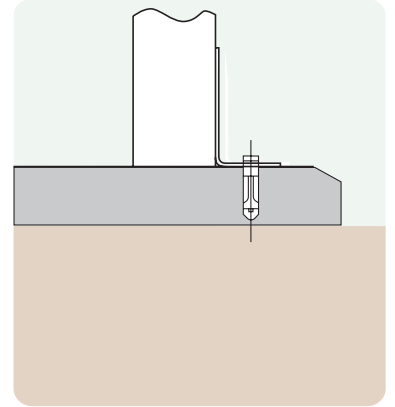

FastDek
Envirofriendly alternative to a concrete pad.

Isometric View

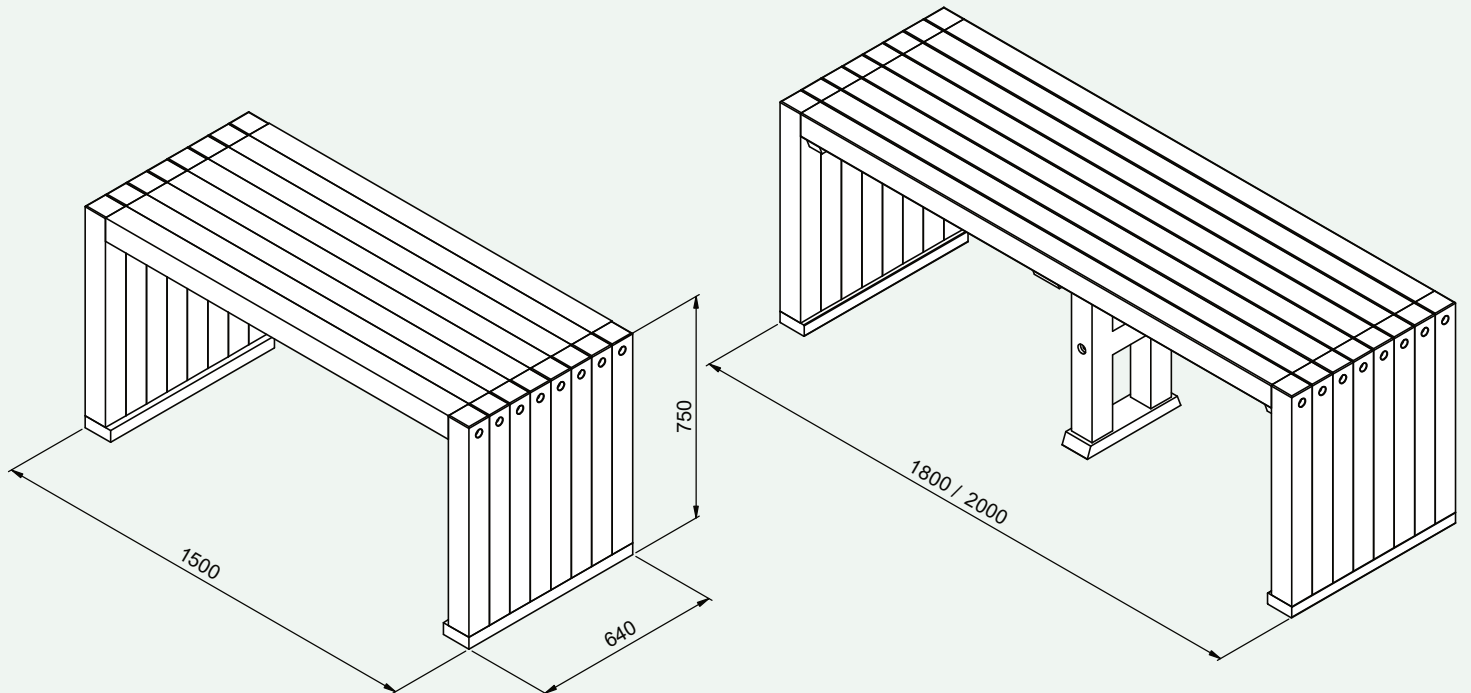

Earth Anchors Ltd

Unit 3 Io Centre, Salbrook Road Industrial Estate, Salfords, Surrey, RH1 5GJ

Tel: 020 8684 9601

www.earth-anchors.com